

INSTRUCTION SHEET FOR MODEL FK60 FLASHING LIGHT KIT

SAFETY MESSAGE TO INSTALLERS

People's lives depend on your safe installation of our products. It is important to read, understand and follow all instructions shipped with the products. In addition, listed below are some other important safety instructions and precautions you should follow:

- To properly install this kit: you must have a good understanding of automotive electrical procedures and systems, along with proficiency in the installation and use of safety warning equipment.
- You should frequently inspect the light system to ensure that it is operating properly and that it is securely attached to the vehicle.
- Refer to the instruction sheets packed with related products for additional precautions and information.
- File these instructions in a safe place and refer to them when maintaining and/or re-installing the product.

Failure to follow all safety precautions and instructions may result in property damage, serious injury, or death to you or others.

A. GENERAL.

The Model FK60 flashing light kit is designed for installation in Federal Model JSTRM-60B. Flashing lights are designed to provide an alternating flash to the front or rear of the light assembly.

If installation of the FK60 in another mounting location or in any other product is chosen, the safety and effectiveness of the final design must be carefully evaluated.

After unpacking the flashing light kit, carefully check all envelopes, shipping labels and tags before removing or destroying them. Ensure that the parts listed in the KIT CONTENTS LIST are contained in the packing carton.

B. KIT CONTENTS LIST.

Qty.	Description	Part Number
1	Flasher	8554B010
2	Reflector Assembly	8552A269-01
2	Lamp, 12V, 35W, #796	8548A028
2	Screw, Hex Hd., Thd. Frm., #10-32	7011A067-06
1	Adhesive Pad	8537A533
1	Wire, 18AWG, WHT/RED, 31"	T300A218-22-0015
1	Wire, 18AWG, WHT/RED, 18"	T300A218-22-0016
1	Wire, 18AWG, WHT/BLK	T300A218-29-0012
1	Lockwasher, #10	7075A014

C. INSTALLATION FOR FRONT OR REAR FLASHING.

WARNING

If shorted to vehicle frame, high current conductors can cause hazardous sparks resulting in electrical fires or molten metal. Before proceeding, disconnect power to the light assembly at the Positive (+) battery terminal.

1. Select the mounting location for the Model FK60 (see figure 1).
2. Remove and retain the two screws located at the identification plate of each dome assembly. Slide both dome assemblies out of the extrusion.
3. Position the reflector assembly at the selected location facing the front or rear as required. Temporarily install the dome and ensure that the reflector is aligned with the center of the dome insert. Remove the dome and secure the reflector assembly to the extrusion with the #10-32 thread-forming screw (see figure 2). Repeat for the other side.

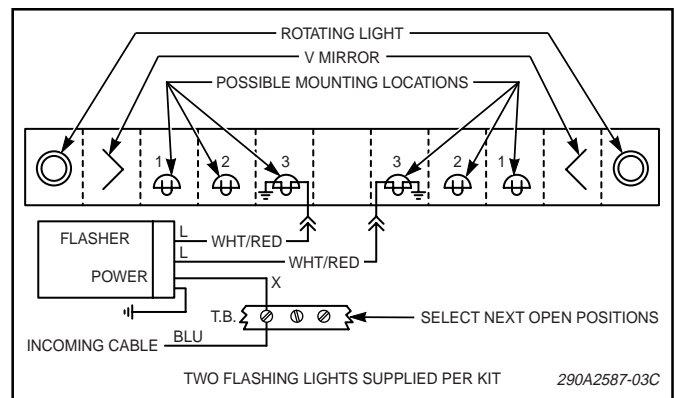

Figure 1.

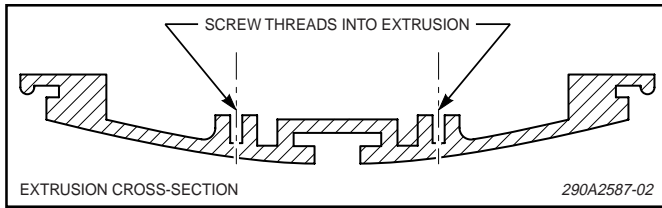

Figure 2.

NOTE

Thoroughly clean and dry both surfaces before affixing pad.

4. Locate the proper position for mounting the supplied flasher (see figure 3). Remove the backing from one side of the adhesive pad (supplied) and affix the pad to the flasher. Remove the backing from the other side of the adhesive pad. Affix the flasher and pad in the desired position. To ensure a good electrical ground, attach the ground wire from the flasher to the extrusion using the #10 screw and lockwasher used to mount the reflector (see figure 3).

5. Connect one end of the WHT/BLK wire to the flasher terminal marked "X". Connect the other end

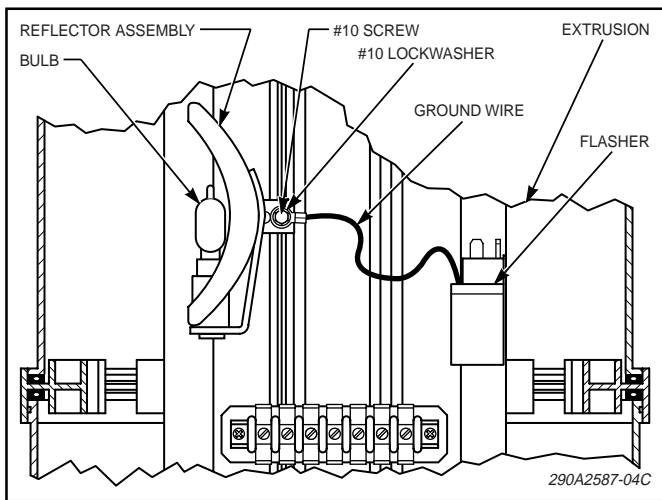

Figure 3.

of the WHT/BLK wire to the terminal block position which connects to the incoming cable's blue wire.

NOTE

Two different lengths of wire are supplied. When performing the wiring, ensure that the proper length wire is used.

6. Connect the male terminal end of a supplied wire (white with red stripe) to the mating terminal at the side of a reflector assembly. Connect the female terminal on the wire's other end to a terminal marked "L" (on the flasher).

7. Connect the male terminal end of the other supplied wire (white with red stripe) to the mating terminal at the side of the other reflector assembly. Connect the female terminal on the wire's other end to the other terminal marked "L" (on the flasher).

CAUTION

Service life of lamp will be shortened if glass portion is touched. If glass has been handled, clean carefully with a grease solvent.

8. Install a lamp (supplied) in the socket in each reflector assembly.

CAUTION

Interference with a rotating reflector can damage the reflector or wires. Ensure that wires are dressed to prevent any interference.

9. Reinstall the domes and secure with the previously removed screws. Reconnect power to the light assembly.

10. Check for proper operation of all functions.