

**INSTRUCTION SHEET  
FOR  
MODEL SPL2  
ROTATING LIGHT LENS KIT**

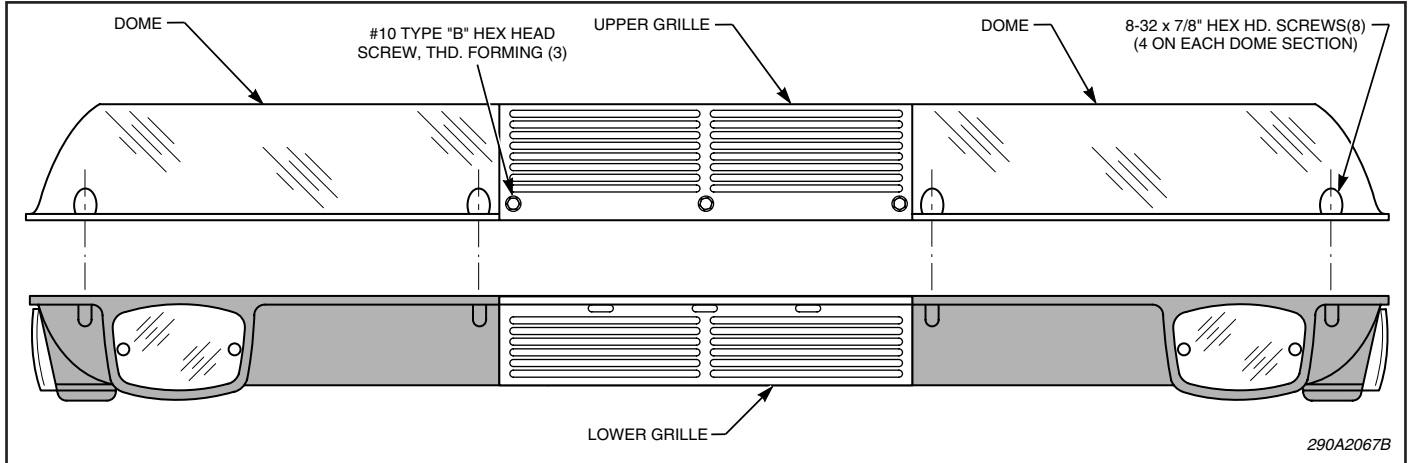

Figure 1.

**A. DOME AND GRILLE REMOVAL (see figure 1).**

1. Turn-off power to Light Assembly.
2. Remove three (3) type "B" hex washer head thread-forming screws which secure the upper speaker grille to the lower speaker grille. Lift upper grille away from lower grille.
3. Remove the eight (four on each side) #8-32 x 7/8" hex head screws from the front and rear edges of the dome.
4. Carefully remove the domes. Ensure that the bulkhead gasket remains tucked in its groove.

**B. INSTALLATION OF LIGHT LENS (see figure 2).**

**CAUTION**

Excessive tightening of the #8 x 1/2" type "B" screw will damage the colored lens and plastic reflector bracket.

Secure the colored lens and shield bracket with the #8 x 1/2" type "B" screw.

**C. REPLACEMENT OF DOME AND GRILLE.**

Reverse the procedure described in A.1, 2, 3 and 4. Torque dome screws to 14-18 in./lbs and grille screws to 20-25 in./lbs.

**D. LENS CLEANING.**

**WARNING**

Crazing (cracking) of lenses will cause reduced effectiveness of light system. Do not use cleaning agents (which will cause crazing) such as strong detergents, solvents, or petroleum products. If crazing of lenses does occur, reliability of light for emergency purposes may be reduced until lenses are replaced.

Ordinarily the lens can be cleaned by using mild soap and a soft rag. Should fine scratches or a haze appear on the lens, they can ordinarily be removed

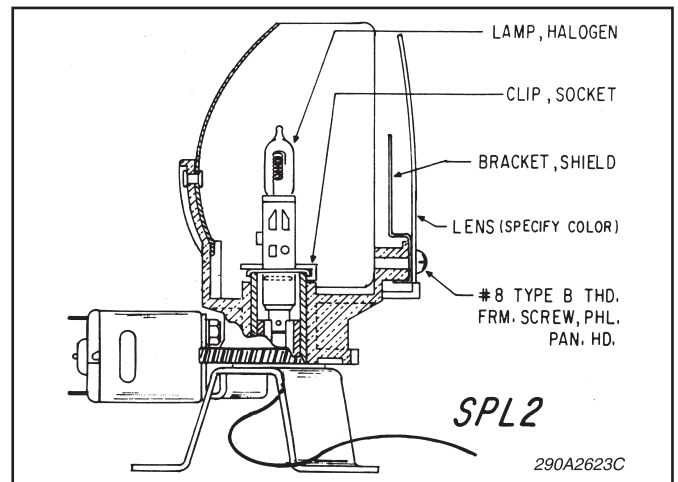

Figure 2.

with a non-abrasive, high quality, one-step, automotive paste cleaner/wax and a soft cloth.

#### E. KIT CONTENTS.

Qty.	Description
1	Lens
1	Bracket, Shield
1	Screw, #8 x 1/2", Type B

#### F. LAMP REPLACEMENT.

1. Remove the dome and grill as described in paragraph A.
2. Remove the colored lens and shield bracket.

**⚠ CAUTION**

Forced rotation of the light mechanism will cause damage to the worm gear. ALWAYS rotate the light mechanism by rotating the motor shaft.

3. Rotate the reflector until the lamp clip (located at the base of the lamp) can be removed, and remove the clip by sliding it away from the reflector.

4. Note the lamp's orientation and pull the defective lamp and connector out of the socket.

**⚠ WARNING**

A serious injury may result if lamp is touched when hot. Always allow lamp to cool before removing. Halogen lamps are pressurized and if broken can result in flying glass. Always wear gloves and eye protection when handling the lamps.

**⚠ CAUTION**

When installing a new lamp, do not touch the glass portion. If the glass has been touched, shortened lamp life will result. If the glass end has been handled, it should be carefully cleaned with a grease solvent.

5. Replace the defective lamp with a new H-1 halogen lamp (Federal Part No. 8440A265A). When reassembling, ensure that the lamp is secured to the connector and that the clip is properly seated in the grooves on the lamp socket.

6. Replace the dome and grille as described in paragraph C.