

# WHELEN<sup>®</sup>

ENGINEERING COMPANY INC.

51 Winthrop Road  
Chester, Connecticut 06412-0684  
Phone: (860) 526-9504  
Fax: (860) 526-4078  
Internet: [www.whelen.com](http://www.whelen.com)  
Sales e-mail: [autosale@whelen.com](mailto:autosale@whelen.com)  
Canadian Sales e-mail: [autocan@whelen.com](mailto:autocan@whelen.com)  
Customer Service e-mail: [custserv@whelen.com](mailto:custserv@whelen.com)

## Installation Guide: Edge<sup>®</sup> Ultra, Edge Freedom<sup>™</sup>, LFL Liberty<sup>™</sup> & LFL Patriot<sup>™</sup> SC Series Lightbars

### Safety First

This document provides all the necessary information to allow your Whelen product to be properly and safely installed. Before beginning the installation and/or operation of your new product, the installation technician and operator must read this manual completely. Important information is contained herein that could prevent serious injury or damage.

- Proper installation of this product requires the installer to have a good understanding of automotive electronics, systems and procedures.
- If mounting this product requires drilling holes, the installer **MUST** be sure that no vehicle components or other vital parts could be damaged by the drilling process. Check both sides of the mounting surface before drilling begins. Also de-burr any holes and remove any metal shards or remnants. Install grommets into all wire passage holes.
- If this manual states that this product may be mounted with suction cups, magnets, tape or Velcro<sup>®</sup>, clean the mounting surface with a 50/50 mix of isopropyl alcohol and water and dry thoroughly.
- Do not install this product or route any wires in the deployment area of your air bag. Equipment mounted or located in the air bag deployment area will damage or reduce the effectiveness of the air bag, or become a projectile that could cause serious personal injury or death. Refer to your vehicle owner's manual for the air bag deployment area. The User/Installer assumes full responsibility to determine proper mounting location, based on providing ultimate safety to all passengers inside the vehicle.
- For this product to operate at optimum efficiency, a good electrical connection to chassis ground must be made. The recommended procedure requires the product ground wire to be connected directly to the **NEGATIVE (-)** battery post.
- If this product uses a remote device to activate or control this product, make sure that this control is located in an area that allows both the vehicle and the control to be operated safely in any driving condition.
- Do not attempt to activate or control this device in a hazardous driving situation.
- This product contains either strobe light(s), halogen light(s), high-intensity LEDs or a combination of these lights. Do not stare directly into these lights. Momentary blindness and/or eye damage could result.
- Use only soap and water to clean the outer lens. Use of other chemicals could result in premature lens cracking (crazing) and discoloration. Lenses in this condition have significantly reduced effectiveness and should be replaced immediately. Inspect and operate this product regularly to confirm its proper operation and mounting condition. Do not use a pressure washer to clean this product.
- It is recommended that these instructions be stored in a safe place and referred to when performing maintenance and/or reinstallation of this product.
- **FAILURE TO FOLLOW THESE SAFETY PRECAUTIONS AND INSTRUCTIONS COULD RESULT IN DAMAGE TO THE PRODUCT OR VEHICLE AND/OR SERIOUS INJURY TO YOU AND YOUR PASSENGERS!**

**For warranty information regarding this product, visit [www.whelen.com/warranty](http://www.whelen.com/warranty)**

**IMPORTANT!** The lightbar should be a minimum of 16" from any radio antennas!

### Mounting your Lightbar:

Refer to the Lightbar mounting guide included with the lightbar

### Routing your Lightbar Cable(s):

- To protect the headliner from damage caused by drilling the cable access hole through the vehicle roof, allow a 5" to 7" distance between roof and headliner by lowering the headliner before drilling.
- Using a 1" hole saw, drill the cable access hole.

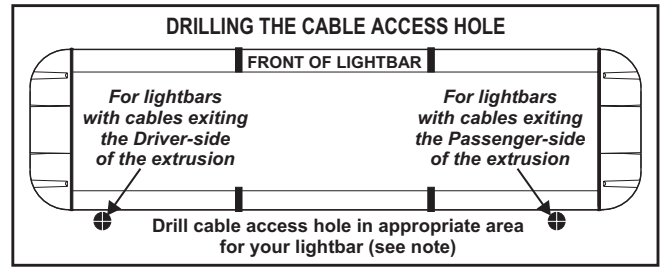

**NOTE:** There may be a roof support member that spans the distance between the driver's and passenger's side. **DO NOT DRILL THROUGH THIS MEMBER!** Adjust the location until the hole can be drilled without contacting this support member.

- Use a round file to smooth and de-burr the edges of the hole.
- Insert a 1" grommet (user supplied) into the cable access hole.
- Insert the cable(s) through the cable access hole into the vehicle. Use RTV silicone to weatherproof the access hole after the cable(s) are pulled completely into the vehicle.
- Route the cable(s) down through the B-pillar. The cable(s) must make a 90° turn to enter the B-pillar. Although routing the cable in this manner may be difficult, this has been determined to be the best procedure. It is up to the installation technicians discretion whether to route the cable(s) as recommended or use an alternative route. Pull the full length of the cable(s) out of the hole at the base of the B-pillar (Fig. 1) and route towards your switch panel. Refer to the instructions included with your switches for switch wiring information.

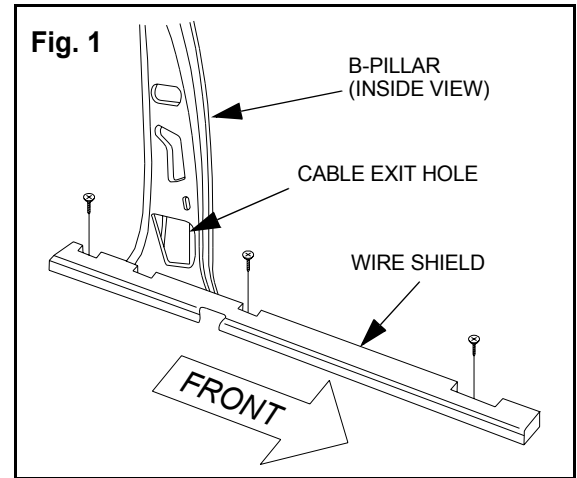

### Connecting the Power Cable . . .

- Open the wiring shield lid (Fig. 3) and route the power cable into the wiring shield and towards the firewall.
- Follow the factory wiring harness through the firewall. It may be necessary to drill a hole in the firewall. If so, be absolutely sure that there are no components that could be damaged by drilling. After the hole has been drilled, insert a grommet to protect the cable.
- Route the cable along the factory wiring harness towards the battery. Install a 40 Amp fuse block (customer supplied) on the end of the RED wire in the power cable. **NOTE: Remove the fuse from the fuse block before connecting any wires to the battery.**

**WARNING!** All customer supplied wires that connect to the positive terminal of the battery must be sized to supply at least 125% of the maximum operating current and **FUSED** at the battery to carry that load. **DO NOT USE CIRCUIT BREAKERS WITH THIS PRODUCT!**

- Insert the supplied mounting screws into these holes and tighten firmly. Repeat for passenger side of the vehicle.
- Firmly tighten the tension bolts to secure the lightbar to the vehicle.

### Connecting the Communication Cable . . . With BL627 Siren Amplifier:

- Route the communication cable into the wiring shield, along the factory wiring harness and into the trunk.
- Route the communication cable towards the communication port on the BL627. Cut the communication wires to length.
- Strip approximately 1/4" of insulation off both the BLUE and the GREY wires. Insert these wires into the central communication port on the BL627. Secure these wires with a small, flat-blade screwdriver.

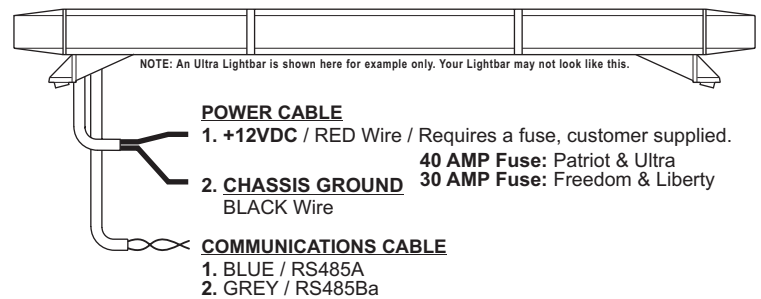

### Without BL627 Siren Amplifier:

Splice the BLUE and GREY wires from the lightbar to the BLUE and GREY wires in the 4-conductor MPC cable.

### Troubleshooting:

Your lightbar should now be fully operational. If it is not functioning properly, check your connections for the following:

- The positive wire (RED) is properly connected to the battery, by way of the user supplied fuse block.
- A working fuse of the correct amperage is installed in the fuse block (See illustration above, for the specific fuse rating for your lightbar).
- The ground wire (BLACK) is properly connected to the factory ground. Be sure that the wire is fully grounded to this location.
- The two communication wires (BLUE and GREY) are properly connected to their communication designations.

If these connections are good, contact your Whelen representative for further assistance.

Control of your lightbar is handled through the MPC. Although your MPC has been programmed to your specifications at the factory, be sure to familiarize yourself with its controls and their functions before initial field operation.