

**INSTRUCTION SHEET  
FOR  
MODEL HK-RAM2**

**SAFETY MESSAGE TO INSTALLERS  
OF  
FEDERAL SIGNAL LIGHT SYSTEMS**

People's lives depend on your safe installation of our products. It is important to read, understand and follow all instructions shipped with the products. In addition, listed below are some other important safety instructions and precautions you should follow:

- To properly install a light assembly: you must have a good understanding of automotive electrical procedures and systems, along with proficiency in the installation and use of safety warning equipment.
- When drilling into a vehicle structure, be sure that both sides of the surface are clear of anything that could be damaged.
- You should frequently inspect the light system to ensure that it is operating properly and that it is securely attached to the vehicle.
- Refer to the instruction sheets packed with related products for additional precautions and information.
- File these instructions in a safe place and refer to them when maintaining and/or reinstalling the product.

Failure to follow all safety precautions and instructions may result in property damage, serious injury, or death to you or others.

**A. GENERAL.**

This instruction sheet provides additional directions for installation of a separately purchased mounting system for the Federal AeroDync® Series, JetSonic® Series, JetStream™ Series, or JetStrobe™ Series light assemblies, and the Vision™ warning system on Dodge Ram vehicles.

**NOTE**

Installation of the Model HK-RAM2 requires the use of parts from the mounting system kit.

**B. UNPACKING.**

After unpacking the kit, carefully check all envelopes, shipping labels, and tags before removing or destroying them. Ensure that the parts shown in the KIT CONTENTS are contained in the packing carton.

**C. KIT CONTENTS.**

Qty.	Description	Part Number
2	Hook	8552587
6	Screw, #10 Thd. Frm	7011A119-08

**D. INSTALLATION.**

**NOTE**

Before proceeding, read and understand all instructions packed with the mounting system kit.

1. Place the light assembly on the roof to determine desired mounting location. (Refer to the instructions packed with mounting kit.)

**NOTE**

The mounting hooks (if any) included with the mounting kit will not be used for this installation.

2. See figure 1. The vehicle's weather stripping must be removed to properly mount the hook. To remove the weather stripping from the vehicle, loosen the torx screws.

3. Ensure that the adjustment bolt holes in the hook and the mounting bracket are properly aligned. Use the hook as a template to mark three drill position marks.

**CAUTION**

To avoid damage when drilling, ensure that both sides of mounting surface are clear of any parts or wires.

Also, when drilling holes, ensure that holes are drilled only through sheet metal and NOT through upholstery.

4. Drill three (3) 0.147" diameter holes (#26 drill bit) at the drill position marks. Secure the hook using three #10 thread-forming sheet metal screws. Assemble the hook on the mounting bracket using the appropriate 5/16-18 torx head bolt (finger-tight only).

5. Repeat steps 2, 3, 4, and 5 with the other hook.

**CAUTION**

Maintain hook mounting adjustment bolt torque of 10 - 11 ft-lbs. Failure to do so may result in damage to the vehicle and/or injury to others.

6. Tighten the adjustment bolts to ensure that the light bar is securely anchored to the hooks. Excessive tightening will distort and damage the vehicle roof.

7. Replace the vehicle's weather stripping.

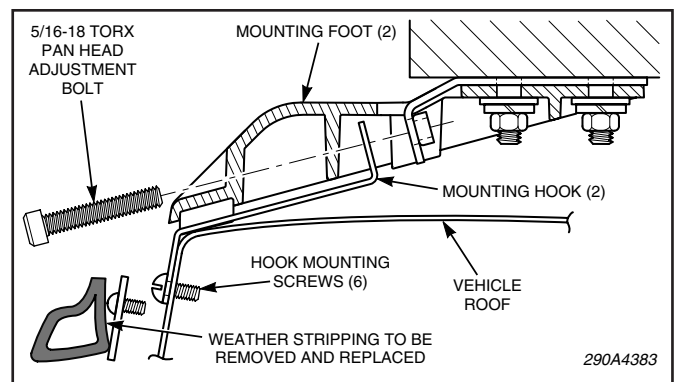

Figure 1.

290A4383